



YOW CHENG **YC-NCP** CNC Boring Machine



YOW CHENG YC-NCP CNC Boring Machine

佑盛YC-NCP CNC鑽孔機

- A machine that combines multiple-spindle boring and grooving functions in one.
- Advanced CNC controller features ease of operation.
- X, Y, Z-axis feeds are all driven by servo motors.
- Slideways of Y, Z-axis and side pressure plate are mounted with linear guide ways.
- Fully enclosed splash guard.
- 融合多軸鑽孔與打溝於一機
- 先進CNC控制，操控簡易
- X, Y, Z軸進給全伺服馬達驅動
- Y, Z軸及側壓板滑道裝置線性滑軌
- 全密閉式護罩

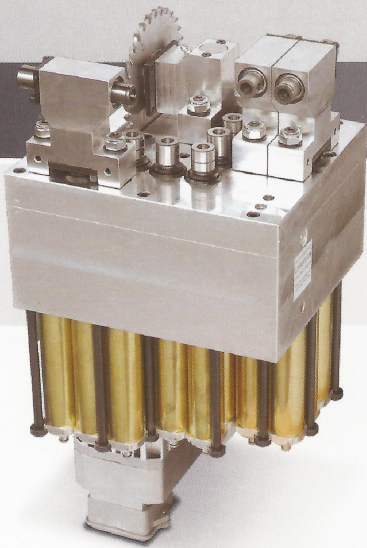

Multi-Spindle Boring Head Unit

The multi-spindle boring head mechanism consists of multiple drills and one sawblade, making the machine suitable for performing vertical boring, side boring and grooving operations.

- **VERTICAL BORING:**
8 drills. Drill shank diameter $\phi 10\text{mm}$.
- **X-AXIS SIDE BORING:**
Two drills at front and two drills at back. Drill shank diameter $\phi 10\text{mm}$.
- **Y-AXIS SIDE BORING:**
One drill at left and one drill at right. Drill shank diameter $\phi 10\text{mm}$.
- **X-AXIS GROOVING SAWBLADE:**
Outside diameter $\phi 120\text{mm}$. Teeth 30. Bore $\phi 20\text{mm}$.

多軸鑽孔頭結構

多軸鑽孔頭由多支鑽頭及鋸片組成，可執行主鑽、側鑽及打溝作業。

- 主鑽：8支鑽頭。鑽頭柄 $\phi 10\text{mm}$
- X軸側鑽：前面2支，後面2支鑽頭。鑽頭柄 $\phi 10\text{mm}$
- Y軸側鑽：左邊1支，右邊1支鑽頭。鑽頭柄 $\phi 10\text{mm}$
- X軸打溝鋸片：外徑 $\phi 120\text{mm}$ ，齒數30，孔徑 $\phi 20\text{mm}$

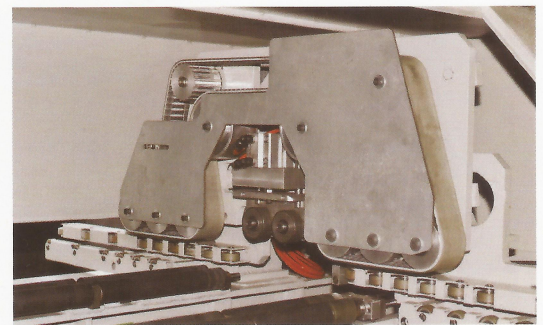
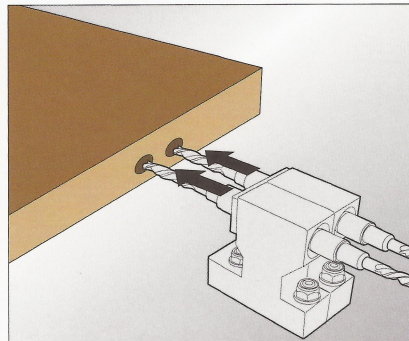
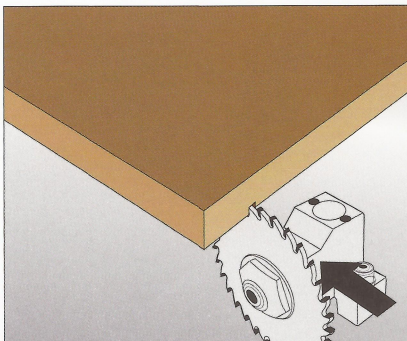
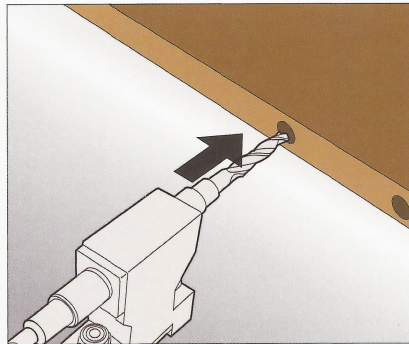
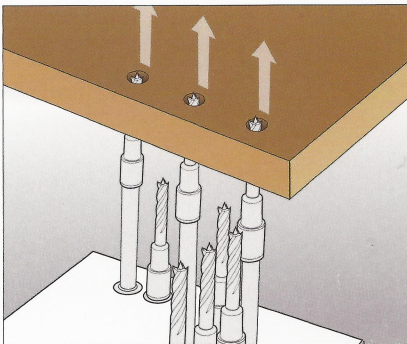

Panel Clamping Mechanism

- Elevation of the panel clamping mechanism is actuated by an air cylinder, and is controlled by a foot switch.
- Pressure rollers can rotate clockwise and counter-clockwise.
- Equipped with an encoder allowing automatic compensation for panel positioning.

壓料座

- 壓料輪生將採用氣壓缸致動。並以腳踏開關控制
- 壓料輪可正逆轉
- 附有譯碼器，提供木料定位自動補償功能

Exceptional Efficiency in Boring and Grooving Optimal Operational Performance

高效率鑽孔打溝 最佳操控性



YOW CHENG

Heat Exchanger for Electrical Cabinet

- The electrical cabinet is equipped with a heat exchanger to ensure a constant temperature in the control circuit.

Stable Control Performance

- The control system utilizes high quality electronic components complying with European Standards.
- The electrical cabinet features water-proof and dust-proof.
- Neat wiring for added convenience in maintenance.

電氣箱熱交換器

- 電氣箱附有熱交換器，以確保控制迴路之常溫運作。

穩定的控制性能

- 電控系統採用高級電子元件，符合歐規標準。
- 電氣箱具防水、防塵效果。
- 配線整齊，維修保養方便。

CNC 控制器

- Windows XP 作業系統
- 工業級PC電腦
- 15" LCD 圖形對話式操作介面
- CAD/CAM功能
- X, Y, Z軸自動原點復歸
- 中、英文畫面顯示

CNC Controller

- Windows XP operation system
- Industrial grade PC computer
- 15" LCD graphical conversational operation interface
- CAD/CAM function
- Automatic home position return on X, Y, Z-axis.
- Chinese / English language display.



M.P.G. Handwheel

- It provides manual movement of X, Y, Z-axis movement and makes setup convenient.

電子手輪

- 提供X, Y, Z軸之手動移動，使校機更方便。



Foot Switch

- For actuating home positioning pin.
- Also for controlling panel clamp and unclamp.

腳踏開關

- 可致動原點定位梢。
- 壓料及鬆料控制。



Connecting Ports for Operation Interface

- USB / Mouse / Keyboard

操作介面連接埠

- USB / 滑鼠 / 鍵盤。

YOW CHENG **YC-NCP** CNC Boring Machine

規格 Specifications:

Model	機種	YC-NCP
Max. quantity of horizontal spindles	水平最大主軸數目	2 + 2
Max. quantity of vertical spindles	垂直最大主軸數目	8
X-axis feed rate	X軸移動速度	30 m/min
Y-axis feed rate	Y軸移動速度	30 m/min
Z-axis feed rate	Z軸移動速度	15 m/min
X-axis machining size	X軸加工尺寸	270~3000 mm
Y-axis machining size	Y軸加工尺寸	150~920 mm
Z-axis machining size	Z軸加工尺寸	12~50 mm
Distance between horizontal holes	水平孔距	32 mm
Distance between vertical holes	垂直孔距	32 mm
Max. horizontal hole diameter	水平最大孔徑	12 mm
Max. vertical hole diameter	垂直最大孔徑	N°8 x 12 mm
Max. horizontal boring depth	水平最大鑽孔深度	30 mm
Max. vertical boring depth	垂直最大鑽孔深度	45 mm
Spindle motor	主軸馬力	1.5 kw 2.27HP
Working pressure	使用壓力	0.6~0.8 MPA
Machine dimensions	機械尺寸	2100 x 1280 x 1600 mm
Packing dimensions	裝箱尺寸	2300 x 1400 x 1610mm
Net weight	淨重	820 kgs
Gross weight	毛重	1020 kgs

- 本公司保有修改機械規格之權力，本型錄內容僅供參考，如有修改恕不另行通知。
- Above information are for reference only. The machine design, specifications and construction are subject to change without prior notice.

選購配件：

- 鉋花主軸頭
- 條碼掃描器

Optional Accessories:

- Routing spindle head
- Barcode scanner



佑盛機械工業有限公司 Yow Cheng Machinery Industry Co., Ltd.

42942 台灣 台中市神岡區豐洲里東洲路111號

No.111 Dong Zhou Rd., Shen Gang Dist., Taichung, Taiwan.

TEL: 886-4-2528 8637 • 2522 5326 FAX: 886-4-2528 8638

<http://www.yowcheng.com.tw>

E-mail: ycmtc@ms64.hinet.net